

NT200 detailed specification

Type of instrument

Alpha/beta counter optimised for smear (wipe) samples and air filters. User-friendly software with direct presentation in contamination units or activity. Built-in printer.

Size and weight

Width 186 mm (7.3")
 Depth 260 mm (10.2")
 Height 240 mm (9.4")

Working area including sample holder and cables:

Depth 380 mm (15")
 Width 530mm (20.9")

Total weight: 47 kg (104 lb)

The NT200 can easily be disassembled in three parts and each part weights less than 25 kg (55 lb).

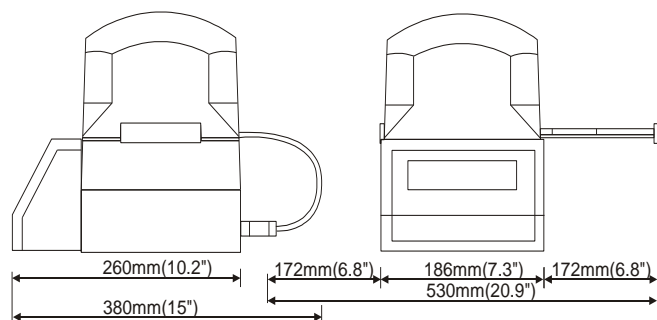

Lead shield

Geometry: 4π
 Thickness: Nominally 50 mm (2"). Varying between 60 mm to 43 mm (2.4" to 1.7")

Detector

Permanently sealed proportional detector.

Gas filling: Argon, CO₂
 Gas pressure: 850mBar
 Cathode material: Stainless steel
 Outer diameter: 54 mm (2.1")
 Active window diameter: 44 mm (1.7")
 Nominal working voltage: 1350-1450V
 Lifetime at working voltage: 10¹¹ pulses
 Storage time: > 10 years
 Window material: Mica
 Window density: 2,0 mg/cm²
 Effective area: 15,5 cm²

Typical instrument efficiency

Measuring geometry 2π according to ISO 7503-1. Active diameter of reference source: 45 mm (1.8"). The reference activity is the surface emission rate as specified by the source manufacturer. Measured efficiencies may vary because of source and geometry differences depending on the source manufacturer, cover material, backing material and source calibration method.

Beta emitters	Eff. [%]	E _{βmax} [keV]
Sr-90/Y-90	49	546/2260
Cl-36	44	710
Co-60	35	318
Tc-99	29	294
C-14	22	154
Fe-55	16	electron capture
Alpha emitters		E [keV]
Am-241	32	5638
Pu-239	33	5245
U-238	13	4270

Minimum detectable activity (MDA)

The formula is based on ISO/FDIS 11929-1 and ISO 7503-1.

Typical example for Co-60/Am-241:

Efficiency beta	35%
Efficiency alpha	34%
Background alpha	0,005 cps
Background beta	0,25 cps (0,50 µGy/h)
Sigma, number of	1,65 (confidence level 90%)
Source efficiency	25%
Smear area	300 cm ²
Removal factor	10%

Time [s]	MDA beta [Bq/cm ²]	MDA alpha [Bq/cm ²]
10	0,49	0,25
20	0,30	0,14
30	0,23	0,09
100	0,11	0,03

Background count rate

Measured in a homogenous radiation field from Cs-137.

µGy/h	≤ CPS	
0,1	0,25	Beta mode
1	0,4	
10	0,8	
50	2,5	
100	5	
100	0,01	Alpha mode

Background compensation

The NT200 has two background compensation modes:

Dynamic:

Background is counted during the sample counting. Suitable for areas with increased and/or varying background.

The NT200 has two detectors, one counts the sample and one counts the background. The background detector count is subtracted from the sample detector count (with a correcting factor 0-200%, nominally 100%) and the net count is used to compute the measuring value.

Static:

Background is counted before sample counting. Suitable for areas with normal and/or constant background. The minimum detectable activity (MDA) is lower in this mode because of the longer background measuring time.

The measuring detector background is counted for a longer time than the measuring time (for example 5-10 min). This background count rate is subtracted from the sample count rate and the net count rate is used to compute the measuring value.

Measuring modes

Beta with auto-alpha

Beta only

Alpha only

Alpha and beta

Max display value: 9999 Bq/cm²
 99999 kBq/m²

Display units

Bq/cm², kBq/m², kDPM/dm², Bq, DPM, μ Ci, nCi, CPS, CPM, Bq/m³, counts.

Sample holder

Cup size 52x5 mm or direct insertion of smears under a clip ("mouse trap") depending on sample holder model. Custom holders can be made up to 62 mm (2.4").

Electronics

Computer

Processor: Xilinx FPGA with MicroBlaze processor

Memory: 4 MB DRAM

Real time clock with backup battery (Li/MnO₂, mounted on the main board). 2 serial ports.

Main board

Functional parts: High voltage (HV) supply, counting logic, memory card interface and connectors for computer module.

HV range 0 - 1600V (positive) user settable

Measuring board

Functional parts: Measuring amplifier, discriminator, high voltage bias, optical sensors for the position of the sample holder.

Power supply

Input voltage: 90-264 VAC
Input frequency: 47Hz to 440Hz
Efficiency: 75% typical
Isolation voltage: Input/output 3000VAC
 Input/chassis 1500VAC
Switching frequency: 65kHz, \pm 5kHz
Approvals and standards EN60950, IEC950,
 UL1950, VDE0805,
 CSA C22.2 No.950
Max input current: 120VAC 1.4A RMS
 230VAC 0.7A RMS
Power consumption: 9W normal operation
 ~20W peak while printing

Power supply NT200DC

Input voltage: 10-36 VDC
Input current at 12V: \leq 0,6 A normal operation
 \leq 2 A peak while printing
Protection against reverse
voltage: Yes, indefinite

Memory card (option)

Used for software upgrades and the external keyboard option.

Type: MultiMediaCard, MMC

Capacity: Minimum 16-64 MB

Capacity, number of samples >10 000

Card readers for PC:s available with USB interface.

Display

LCD, Black on White Film STN. Screen saver turns off background light in idle mode. Very bright and easy to read.

Resolution: 256x64 dots.

Dot size: 0,44mm square

Dot pitch: 0,47mm square

Viewing angles: 180 degrees.

Background light High brightness CFL,
 white light.

Printer

Type: Thermal line dot system

Paper width: 58mm (2.3")

Resolution: 8 dots/mm

No. of dots/line: 384

No. of characters/line: 24

Print width (mm): 48

Paper thickness (μ m): 65 \pm 5

Paper roll: 58mm x 25m

Paper roll outer diameter: \leq 48mm

Environmental

Operating temperature: 0-40°C (32-104°F).

Operating humidity: 0-90% relative, non-condensing.

Address
NUTRONIC AB
Utjordsvägen 9N
S-802 91 Gävle
Sweden

Telephone
+46-26 65 88 50

Fax
+46-26 65 88 51

e-mail
info@nutronic.se

Homepage
http://www.nutronic.se

Software

The NT200 incorporates user-friendly software with menus for all settings. The settings can be protected with a password.

The software is stored on a flash disk on the computer module. The software is upgrading by inserting a memory card in a slot in the back of the NT200.

Warranty

Note: Warranty conditions can vary depending on agreements with local distributors. Nutronic AB warrants all products for parts and labour for twelve (12) months after delivery. The warranty does not cover accidental damage to the detector window. The warranty is not valid if the product is clearly misused, mistreated or not operated according to the user manual.

Applicable standards

The NT200 adhere to the following international and national standards:

IEC 325 Alpha, beta and alpha-beta contamination meters and monitors.

ISO 7503-1 Evaluation of surface contamination — Part 1: Beta-emitters (maximum beta energy greater than 0,15MeV) and alpha-emitters.

ISO 8769 Reference sources for the calibration of surface contamination monitors — Beta-emitters (maximum beta energy greater than 0,15MeV) and alpha-emitters.

ISO/FDIS 11929-1 Determination of the detection limit threshold for ionising radiation measurements — Part 1: Fundamentals and application to counting measurements without the influence of sample treatment.

France: CODE DU TRAVAIL Article R234-6
(Fair Labour Standards Act)

Options

DC option

Same as base model except: Powered from 10-36VDC.
External mains adapter 100-240VAC-12VDC included.
Cable with battery clips included.

Keyboard/memory card option

External keyboard with MultimediaCard (MMC) memory card slot, 1 MMC memory card and software that allows the user make comments for each sample. The measuring series is stored as an Excel file with the date, the time, the measuring value and the user comment for each sample. The memory card can be read in an external Windows PC with an appropriate card reader for further processing or storage.

MMC memory card reader for USB

Small MMC memory card reader for the USB-bus.

The information herein was valid at the time of writing and is considered by Nutronic AB to be as accurate as possible. Nutronic AB make no expressed or implied warranty of any kind for the contents of this specification or assume any responsibility for errors or omissions. Nutronic reserves the rights to make changes, without further notice, to any products or procedures mentioned in this specification. Some features may be subject to change with future software updates.

Address
NUTRONIC AB
Utjordsvägen 9N
S-802 91 Gävle
Sweden

Telephone
+46-26 65 88 50

Fax
+46-26 65 88 51

e-mail
info@nutronic.se

Homepage
http://www.nutronic.se